

# Germline Mutations in *CTNNB1* Associated With Syndromic FEVR or Norrie Disease

Wenmin Sun, Xueshan Xiao, Shiqiang Li, Xiaoyun Jia, Panfeng Wang, and Qingjiong Zhang

State Key Laboratory of Ophthalmology, Zhongshan Ophthalmic Center, Sun Yat-sen University, Guangzhou, China

Correspondence: Qingjiong Zhang, State Key Laboratory of Ophthalmology, Zhongshan Ophthalmic Center, Sun Yat-sen University, 54 Xianlie Road, Guangzhou 510060, China; zhangqji@mail.sysu.edu.cn.

Submitted: June 26, 2018  
Accepted: November 26, 2018

Citation: Sun W, Xiao X, Li S, Jia X, Wang P, Zhang Q. Germline mutations in *CTNNB1* associated with syndromic FEVR or Norrie disease. *Invest Ophthalmol Vis Sci*. 2019;60:93–97. <https://doi.org/10.1167/iovs.18-25142>

**PURPOSE.** Germline and somatic mutations in *CTNNB1* have been found in different types of human diseases. This follow-up study aimed to identify causative germline mutations in *CTNNB1* and their associated ocular phenotypes through a comparative analysis of whole-exome sequencing data.

**METHODS.** Annotated sequence variations in *CTNNB1* were selected from in-house data from whole-exome sequencing of genomic DNA prepared from leucocytes of 3280 unrelated probands with different forms of eye diseases. Potentially pathogenic variants in *CTNNB1* were analyzed by multistep bioinformatics analyses. Clinical data from probands with pathogenic variants in *CTNNB1* were collected, and potential genotype-phenotype correlations were analyzed.

**RESULTS.** Eleven rare variants that potentially affect the coding regions of *CTNNB1* were detected in 11 of the 3280 samples, and four variants were considered to be potentially pathogenic. All four mutations, namely, c.999delC (p.Tyr333\*), c.1104delT (p.His369Thrfs\*2), c.1738\_1742delinsACA (p.Leu580Thrfs\*28), and c.1867C>T (p.Gln623\*), were heterozygotes and considered to have a germline origin. Three of the four mutations are de novo mutations, and the status of the remaining mutation is unavailable. All four probands had the same class of closely related ocular diseases: one proband had FEVR, and three probands had Norrie-like retinopathy. The molecular results indicated that three probands showed systemic anomalies, as demonstrated by a follow-up survey, but relevant information for the remaining proband was unavailable.

**CONCLUSIONS.** The data suggest that germline truncating mutations in *CTNNB1* cause autosomal dominant syndromic FEVR or Norrie disease. Patients with mutations in *CTNNB1*, *KIF11*, or *NDP* may have similar or overlapping phenotypes, but this phenomenon needs to be studied further.

**Keywords:** *CTNNB1*, mutation, FEVR, Norrie

The *CTNNB1* gene encodes the beta-catenin protein, which is a key transcriptional co-activator of the Wnt/ $\beta$ -catenin signaling pathway and is essential for embryonic development, adult tissue homeostasis, stem cell regulation, and tumorigenesis.<sup>1</sup> Somatic mutations in *CTNNB1* have been reported to be associated with many types of cancer, and germline mutations in the gene have been identified in patients with intellectual disabilities<sup>2–8</sup> and autism spectrum disorders<sup>9,10</sup> involving multitissue phenotypes.<sup>11–13</sup> Of these patients, 50% display abnormalities in vision, including strabismus,<sup>6,13</sup> hyperopia,<sup>6</sup> myopia,<sup>6</sup> retinal detachment,<sup>14</sup> and lens and vitreous opacities.<sup>14</sup> Recently, mutations in *CTNNB1* have been reported to lead to familial exudative vitreoretinopathy (FEVR) with or without extraocular manifestations.<sup>15</sup>

FEVR is a genetic disorder characterized by abnormalities in peripheral retinal vascularization and exhibits both clinical and genetic heterogeneity. The phenotypes of FEVR vary widely, from normal visual acuity with only mild non-perfusion zone in the peripheral retina, as demonstrated by fundus fluorescein angiography, to blindness resulting from retinal detachment.<sup>16</sup> FEVR mostly occurs alone (nonsyndromic) but also can be accompanied by systemic abnormalities, including mental retardation, microcephaly, and

osteoporosis and osteopenia (syndromic).<sup>17–19</sup> In addition, FEVR can occur in an autosomal dominant, autosomal recessive, or X-linked manner, and several genes, including *FZD4*,<sup>20</sup> *LRP5*,<sup>18</sup> *TSPAN12*,<sup>21</sup> and *NDP*,<sup>22</sup> which are involved in the Wnt/ $\beta$ -catenin signaling pathway, and *KIF11*,<sup>17</sup> have been reported to cause FEVR. Mutations in *NDP* can cause both FEVR and Norrie disease,<sup>22</sup> which involves similar vascular dysgenesis of the retina accompanied by microphthalmia, corneal opacity, iris synechia, and mental disorders. Mutations in *KIF11* can cause both nonsyndromic and syndromic FEVR,<sup>17</sup> involving microcephaly and mental retardation, and mutations in the other three genes cause nonsyndromic FEVR. Three heterozygous mutations in *CTNNB1* were recently identified in probands with FEVR: one is associated with syndromic FEVR, and the other two are associated with nonsyndromic FEVR.<sup>15</sup>

Here, we investigated pathogenic variants in *CTNNB1* in 3280 probands with hereditary eye diseases, including 106 probands with FEVR, based on exome sequencing. The results will extend our knowledge of the mutational frequency and spectrum of *CTNNB1*, as well as the potential genotype-phenotype correlations.



TABLE 1. Four Potential Pathogenic Mutations in *CTNNB1* Identified in Patients

Hg19 Position		Nucleotide Change	Amino Acid Change	Patient Status	Patient ID	Allele Frequency in				Novel or Known		
Chr	Position					NM	Patients	1000G	EVS		ExAC	dbSNP
chr03	41268761	NM_001904.3	c.999del	p.Tyr333*	Het	QT2648	1	0	0	0	None	Novel
chr03	41274854	NM_001904.3	c.1104delT	p.His369Thrfs*2	Het	QT1615	1	0	0	0	None	Novel
chr03	41277269	NM_001904.3	c.1738_1742delinsACA	p.Leu580Thrfs*28	Het	QT409	1	0	0	0	None	Novel
chr03	41277903	NM_001904.3	c.1867C>T	p.Gln623*	Het	QT1504	1	0	0	0	None	Novel

Hg19 position refers to human GRCh37/hg19 version from the UCSC genome. Chr, chromosome; Het, heterozygous.

## MATERIALS AND METHODS

A total of 3280 unrelated probands with different hereditary eye diseases (106 probands with FEVR and 3174 probands with other genetic eye diseases, including retinal degeneration, high myopia, glaucoma, hyperopia, and ocular dysplasia) were recruited to participate in this study. Peripheral blood samples and clinical data were collected from each proband, and genomic DNA was obtained from leucocytes isolated from the peripheral blood samples. In accordance with the tenets of the Declaration of Helsinki, written informed consent was obtained from all the participants or their guardians before the study. This study was approved by the Institutional Review Board of the Zhongshan Ophthalmic Center.

Whole-exome sequencing of the genome of all 3280 probands was performed by Macrogen (<http://www.macrogen.com/en/main/index.php>). In brief, genomic DNA from each proband was captured using an Agilent SureSelect Human All Exon Enrichment V5 Kit (50M; Agilent, Santa Clara, CA, USA), and the exome-enriched DNA fragments were then sequenced using the Illumina HiSeq4000 system (Illumina, San Diego, CA, USA). The average sequencing depth was at least 125-fold. Variant calling and annotation were performed using SAMtools (<http://samtools.sourceforge.net/>) and ANNOVAR (<http://annovar.openbioinformatics.org/en/latest/>), respectively.

The variants in *CTNNB1* were selected and analyzed through a multistep bioinformatics analysis as follows: low-certainty variant positions with coverage less than 10 were excluded; variants with a minor allele frequency  $\geq 0.01$ , as determined based on the dbSNP database, 1000 Human Genome Project, Exome Variant Server (EVS), and Exome Aggregation Consortium (ExAC, Cambridge, MA, USA; <http://exac.broadinstitute.org>; accessed October 15, 2018), were excluded; the variants in noncoding regions and synonymous variants without a splice site change, as determined according to the Berkeley Drosophila Genome Project (in the public domain, <http://www.fruitfly.org/>) or NetGene2 (<http://www.cbs.dtu.dk/services/NetGene2/>), were excluded; the variants predicted to be benign by two online tools, PolyPhen-2 ([\[genetics.bwh.harvard.edu/pph2/\]\(http://genetics.bwh.harvard.edu/pph2/\)\) and SIFT \(<http://sift.jcvi.org>\), were excluded; and the pathogenic variants identified through a comparative analysis of variants among different groups of diseases were filtered.](http://</a></p>
</div>
<div data-bbox=)

A review of the mutations and phenotypes of *CTNNB1* was performed to detect potential genotype-phenotype correlations.

## RESULTS

A total of 11 rare variants that potentially affect the coding regions of *CTNNB1* were detected in 11 of the 3280 samples, and these consisted of 5 missense variants, 2 splicing variants, 2 nonsense variants, and 2 frameshift variants. The five missense variants were identified in four patients with glaucoma and one patient with high myopia, whereas the two splicing variants were identified in one patient with retinitis pigmentosa and one patient with high myopia (Supplementary Table S1). The two potentially pathogenic frameshift variants (c.1104delT, p.His369Thrfs\*2 and c.1738\_1742delinsACA, p.Leu580Thrfs\*28) were identified in two probands with FEVR or Norrie-like retinopathy, and the two potentially pathogenic nonsense variants (c.999del, p.Tyr333\* and c.1867C>T, p.Gln623\*) were identified in two probands with Norrie-like retinopathy (Table 1). The four mutations were classified as loss-of-function (LoF) mutations resulting in protein truncation.<sup>23</sup> This type of mutation is extremely rare in *CTNNB1*, as determined by a review of the ExAC database (<http://exac.broadinstitute.org/gene/ENSG00000168036>; October 15, 2018). Three of the four mutations are de novo mutations, and the status of the remaining mutation is unknown because of the unavailability of genomic DNA from the parents.

The clinical manifestations of the four patients are summarized in Table 2. All four patients were examined before the age of 1 year, and they showed typical temporal dragging of the optic disc or retinal detachment accompanied by a retrolenticular fibrotic mass (Fig. 1, Supplementary Fig. S1). Three of the four patients showed signs of Norrie disease, including microphthalmia, corneal opacity, microcornea,

TABLE 2. Clinical Data of Four Patients With Potential Pathogenic Variants in *CTNNB1*

Patient ID	Mutations	Sex	Age		Best Visual Acuity		First Symptom	Axial Length, mm		Main Phenotype
			at Onset, mo	at Exam, mo	OD	OS		OD	OS	
QT2648	c.[999del];[=]	Female	3	3	NA	NA	NRO	14.00	14.00	IPS; RFM; RD
QT1615	c.[1104delT];[=]	Female	8	8	NA	NA	PVF	19.00	19.00	TTOD, OA, MD
QT409	c.[1738_1742delinsACA];[=]	Male	6	6	NA	NA	NRO	17.30	19.80	CO; OP; TTOD, RD
QT1504	c.[1867C>T];[=]	Male	3	6	NA	NA	NRO	11.80	12.50	CO; MC; OP; CAT; RFM; RD

CAT, cataract; CO, corneal opacity; IPS, iris posterior synechia; MC, microcornea; MD, macular dystrophy; NA, not available; NRO, no response to object; OA, optic atrophy; OD, right eye; OP, occlusion of pupil; OS, left eye; PVF, poor vision fixation; RD, retinal detachment; RFM, retrolenticular fibrotic mass; TTOD, temporal dragging of optic disc.

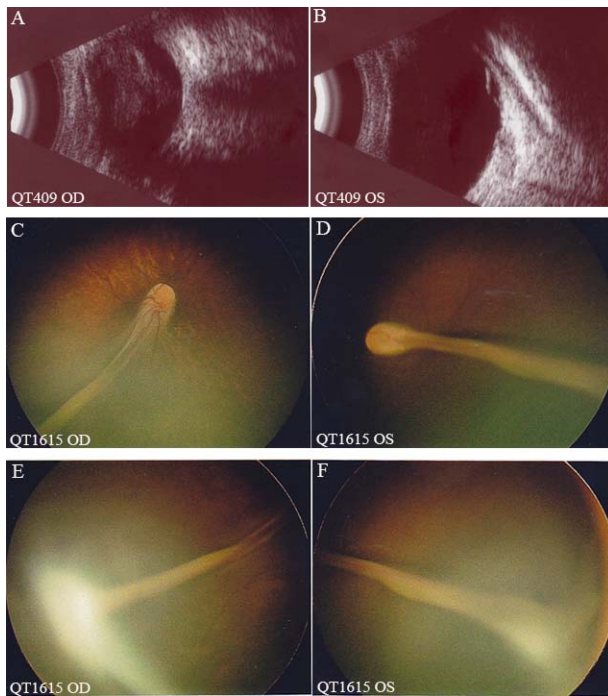

**FIGURE 1.** Fundus changes in patients with mutations in *CTNNB1*. Typical signs of FEVR, including temporal dragging of the optic disc (C-F), falciform retinal fold (E, F), and retinal detachment (A, B), were present. The patient ID is marked at the *bottom left* of each image. OD and OS represent the right and left eyes, respectively. The fundus photographs (C-F) were taken using a RetCam II (lens 1300; Clarity Medical Systems, Pleasanton, CA, USA).

posterior synechia of iris, or pupil occlusion (Table 2). After the molecular results were obtained, the four families were re-contacted. Three of the four probands showed systemic anomalies, as determined via telephone surveys, and the remaining proband was lost to follow-up. The proband QT2648, who is currently 15 months of age, had scoliosis and experienced difficulty in controlling her head. She was also unable to speak, and a cranial computed tomography scan taken when she was 5 months of age showed a local osteolysis lesion on the left parietal, as determined by a review of her medical records. Both proband QT1615 and QT1504 are currently 4 years of age and exhibit autism and learning disabilities. QT1615 showed microcephaly, with a head circumference of 40 cm, when she was 9 months of age.

Since mutations in *CTNNB1* were identified in patients with intellectual disabilities in 2012,<sup>2</sup> 45 mutations have been identified in 56 families with variable diagnoses and phenotypes (Supplementary Table S2).<sup>2-15,24-27</sup> The mutation types and locations in the 56 families with or without eye abnormalities are shown in Figure 2.

**DISCUSSION**

In this study, four truncating mutations in *CTNNB1* were identified in four patients with syndromic FEVR or Norrie disease but not in patients with other eye diseases. These results provide additional evidence for an association of truncating mutations in *CTNNB1* with FEVR or Norrie-like retinopathy.

Nonsense and frameshift mutations in *CTNNB1* are associated with FEVR because of several points. First, the same type of mutations in *CTNNB1* were identified in four

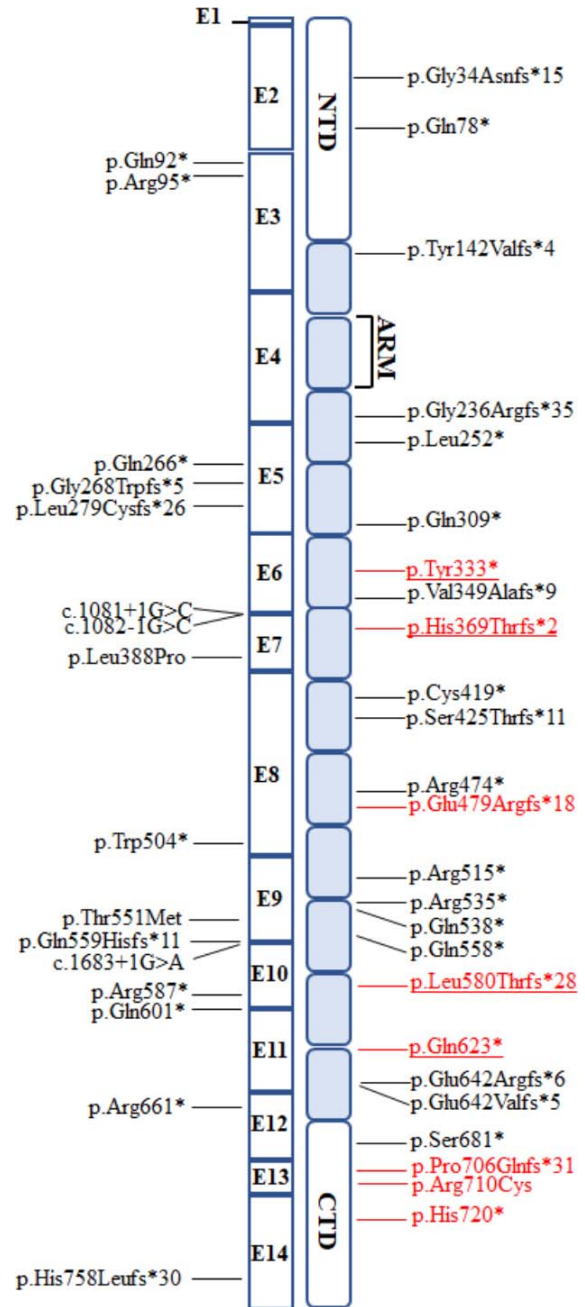

**FIGURE 2.** Mutations in the *CTNNB1* gene. Mutations associated with eye abnormalities are indicated on the *right*, and the mutations associated with FEVR are shown in *red*. Mutations not associated with eye abnormalities are indicated on the *left*.

unrelated patients with the same class of diseases, namely, FEVR or Norrie-like retinopathy. Second, neither nonsense nor frameshift mutations in *CTNNB1* were detected in more than 3000 in-house control individuals in our laboratory or more than 60,000 individuals in the ExAC database. Third, three of the four mutations are de novo, and fourth, all four mutations in *CTNNB1* identified in the current study are LoF mutations, which is consistent with the previous finding that most (92.7%, 38/41) mutations in the gene are LoF mutations (Supplementary Table S2). Moreover, this type of mutation results in the haploinsufficiency of *CTNNB1* by nonsense-mediated mRNA decay<sup>3</sup> and a conditional knockout mouse model of *ctnmb1* established in previous studies showed specific vascular

defects in the central nervous system and retina due to  $\beta$ -catenin depletion.<sup>28,29</sup>

To date, 45 mutations in *CTNNB1* have been identified. With the exception of 3 missense mutations, most of these 45 mutations are truncating mutations (42/45), including 22 nonsense mutations, 15 frameshift mutations, 3 splicing mutations, and 2 gross deletion mutations. The 45 mutations are located in all three domains of the gene, including the four mutations identified in the current study, which are found in the armadillo repeat domain (ARM) (Fig. 2). Twenty-nine mutations are associated with eye abnormalities, and eight mutations can cause nonsyndromic or syndromic FEVR. Nevertheless, there are no differences in the types or locations between mutations associated with eye abnormalities and mutations not associated with eye abnormalities. Of the eight mutations associated with FEVR and Norrie-like retinopathy, five are located in the ARM, the other three are located in the carboxy-terminal domain, and none are located in the amino-terminal domain (Fig. 2). However, a clear genotype-phenotype correlation cannot be obtained due to the small number of cases with FEVR and the lack of a detailed fundus description for most patients with *CTNNB1* mutations.

Most mutations (38/41) in *CTNNB1* were identified in 48 families with intellectual disabilities and autism spectrum disorders in previous studies. Of the 48 families, approximately half (20/48) had eye abnormalities. Three mutations in *CTNNB1* were recently identified in eight patients with FEVR from three families, and one of these patients was diagnosed with FEVR at the age of 4 weeks but displayed features of intellectual disability at the age of 3 years.<sup>15</sup> In the current study, four patients with *CTNNB1* mutations exhibited FEVR or Norrie-like retinopathy, and all of them were examined before 1 year of age due to severe visual defects. The follow-up study after the molecular results were obtained showed that three of the four patients exhibited features of systemic anomalies, including autism, learning disability, motor delay, and scoliosis. The other patient was not available (QT409) but displayed features of Norrie disease. In addition to this study, two previous studies identified two mutations in patients with FEVR or retinal detachment accompanied by intellectual disability, developmental delay, and microcephaly.<sup>14,24</sup> Therefore, variable manifestations of FEVR might be part of the phenotypes resulting from *CTNNB1* mutations. This trend is similar to that found for mutations in *KIF11*, which have been identified in patients with syndromic and nonsyndromic FEVR. Some patients with mutations in *KIF11* are initially diagnosed with FEVR but found to exhibit mental retardation or microcephaly when reexamined after 17 years of age, potentially because intellectual disability is easily ignored in infants. Moreover, Norrie disease is characterized by fibrovascular masses secondary to similar vascular dysgenesis of the retina accompanied by mental disorders. Mutations in *NDP* can cause Norrie disease, and occasionally FEVR. Therefore, similar phenotypes can be caused by mutations in *CTNNB1*, *KIF11*, and *NDP*.

In conclusion, we identified four heterozygous truncating mutations in *CTNNB1* in patients with syndromic FEVR or Norrie disease. Our results provide additional evidence for an association between *CTNNB1* haploinsufficiency and autosomal dominant syndromic FEVR or Norrie disease. Furthermore, mutations in *CTNNB1*, *KIF11*, or *NDP* might cause similar or overlapping phenotypes, but the mechanism needs to be studied further.

### Acknowledgments

The authors thank the patients and the family members for their participation.

Supported by grants from the National Natural Science Foundation of China (U1201221), the Science and Technology Planning Projects of Guangzhou (201607020013), and the Fundamental Research Funds of the State Key Laboratory of Ophthalmology.

Disclosure: **W. Sun**, None; **X. Xiao**, None; **S. Li**, None; **X. Jia**, None; **P. Wang**, None; **Q. Zhang**, None

### References

- Clevers H, Nusse R. Wnt/ $\beta$ -catenin signaling and disease. *Cell*. 2012;149:1192-1205.
- de Ligt J, Willemsen MH, van Bon BW, et al. Diagnostic exome sequencing in persons with severe intellectual disability. *N Engl J Med*. 2012;367:1921-1929.
- Tucci V, Kleefstra T, Hardy A, et al. Dominant beta-catenin mutations cause intellectual disability with recognizable syndromic features. *J Clin Invest*. 2014;124:1468-1482.
- Dubruc E, Putoux A, Labalme A, Rougeot C, Sanlaville D, Ederly P. A new intellectual disability syndrome caused by *CTNNB1* haploinsufficiency. *Am J Med Genet A*. 2014;164A:1571-1575.
- Grozeva D, Carss K, Spasic-Boskovic O, et al. Targeted next-generation sequencing analysis of 1,000 individuals with intellectual disability. *Hum Mutat*. 2015;36:1197-1204.
- Kuechler A, Willemsen MH, Albrecht B, et al. De novo mutations in beta-catenin (*CTNNB1*) appear to be a frequent cause of intellectual disability: expanding the mutational and clinical spectrum. *Hum Genet*. 2015;134:97-109.
- Monroe GR, Frederix GW, Savelberg SM, et al. Effectiveness of whole-exome sequencing and costs of the traditional diagnostic trajectory in children with intellectual disability. *Genet Med*. 2016;18:949-956.
- Winczewska-Wiktor A, Badura-Stronka M, Monies-Nowicka A, et al. A de novo *CTNNB1* nonsense mutation associated with syndromic atypical hyperekplexia, microcephaly and intellectual disability: a case report. *BMC Neurol*. 2016;16:35.
- O'Roak BJ, Vives L, Fu W, et al. Multiplex targeted sequencing identifies recurrently mutated genes in autism spectrum disorders. *Science*. 2012;338:1619-1622.
- Yoo Y, Jung J, Lee YN, et al. *GABBR2* mutations determine phenotype in Rett syndrome and epileptic encephalopathy. *Ann Neurol*. 2017;82:466-478.
- Retterer K, Juusola J, Cho MT, et al. Clinical application of whole-exome sequencing across clinical indications. *Genet Med*. 2016;18:696-704.
- Thevenon J, Duffourd Y, Masurel-Paulet A, et al. Diagnostic odyssey in severe neurodevelopmental disorders: toward clinical whole-exome sequencing as a first-line diagnostic test. *Clin Genet*. 2016;89:700-707.
- Kharbanda M, Pilz DT, Tomkins S, et al. Clinical features associated with *CTNNB1* de novo loss of function mutations in ten individuals. *Eur J Med Genet*. 2017;60:130-135.
- Li N, Xu Y, Li G, et al. Exome sequencing identifies a de novo mutation of *CTNNB1* gene in a patient mainly presented with retinal detachment, lens and vitreous opacities, microcephaly, and developmental delay: case report and literature review. *Medicine (Baltimore)*. 2017;96:e6914.
- Panagiotou ES, Sanjurjo Soriano C, Poulter JA, et al. Defects in the cell signaling mediator beta-catenin cause the retinal vascular condition FEVR. *Am J Hum Genet*. 2017;100:960-968.
- Criswick VG, Schepens CL. Familial exudative vitreoretinopathy. *Am J Ophthalmol*. 1969;68:578-594.
- Robitaille JM, Gillett RM, LeBlanc MA, et al. Phenotypic overlap between familial exudative vitreoretinopathy and microcephaly, lymphedema, and chorioretinal dysplasia caused by *KIF11* mutations. *JAMA Ophthalmol*. 2014;132:1393-1399.

18. Toomes C, Bottomley HM, Jackson RM, et al. Mutations in LRP5 or FZD4 underlie the common familial exudative vitreoretinopathy locus on chromosome 11q. *Am J Hum Genet.* 2004;74:721-730.
19. Qin M, Hayashi H, Oshima K, Tahira T, Hayashi K, Kondo H. Complexity of the genotype-phenotype correlation in familial exudative vitreoretinopathy with mutations in the LRP5 and/or FZD4 genes. *Hum Mutat.* 2005;26:104-112.
20. Robitaille J, MacDonald ML, Kaykas A, et al. Mutant frizzled-4 disrupts retinal angiogenesis in familial exudative vitreoretinopathy. *Nat Genet.* 2002;32:326-330.
21. Nikopoulos K, Gilissen C, Hoischen A, et al. Next-generation sequencing of a 40 Mb linkage interval reveals TSPAN12 mutations in patients with familial exudative vitreoretinopathy. *Am J Hum Genet.* 2010;86:240-247.
22. Chen ZY, Battinelli EM, Fielder A, et al. A mutation in the Norrie disease gene (NDP) associated with X-linked familial exudative vitreoretinopathy. *Nat Genet.* 1993;5:180-183.
23. MacArthur DG, Balasubramanian S, Frankish A, et al. A systematic survey of loss-of-function variants in human protein-coding genes. *Science.* 2012;335:823-828.
24. Dixon MW, Stem MS, Schuette JL, Keegan CE, Besirli CG. CTNNB1 mutation associated with familial exudative vitreoretinopathy (FEVR) phenotype. *Ophthalmic Genet.* 2016;37:468-470.
25. Prasad MK, Geoffroy V, Vicaire S, et al. A targeted next-generation sequencing assay for the molecular diagnosis of genetic disorders with orofacial involvement. *J Med Genet.* 2016;53:98-110.
26. Posey JE, Harel T, Liu P, et al. Resolution of disease phenotypes resulting from multilocus genomic variation. *N Engl J Med.* 2017;376:21-31.
27. Strauss KA, Gonzaga-Jauregui C, Brigatti KW, et al. Genomic diagnostics within a medically underserved population: efficacy and implications. *Genet Med.* 2018;20:31-41.
28. Zhou Y, Wang Y, Tischfield M, et al. Canonical WNT signaling components in vascular development and barrier formation. *J Clin Invest.* 2014;124:3825-3846.
29. Daneman R, Agalliu D, Zhou L, et al. Wnt/beta-catenin signaling is required for CNS, but not non-CNS, angiogenesis. *Proc Natl Acad Sci U S A.* 2009;106:641-646.