

Properties of Anticipatory Vergence Responses

Arun N. Kumar,¹ Yanning Han,¹ Siobhan Garbutt,^{2,3} and R. John Leigh^{1,4}

PURPOSE. To characterize the dynamic properties of vergence eye movements made between near and far targets that were alternately illuminated with predictable timing.

METHODS. Using the magnetic search coil technique, eye movements were measured in 10 normal subjects as they shifted their point of fixation between a near green LED and a distant red laser spot, both aligned on subjects' midlines. Targets were alternately illuminated every 1.25 sec.

RESULTS. All subjects showed some anticipatory responses, consisting of vergence movements that preceded target jumps, accompanied by a small saccade. Group median anticipatory interval was 191 msec. Responses preceded target motion in 83% of divergence trials, and 70% of convergence trials. The velocities of both pre- and postsaccadic components of anticipatory vergence responses were greater when the near target was positioned at 20-cm compared with at 36 cm. In control experiments, in which target presentation was unpredictable, vergence movements preceded stimuli in only approximately 2% of trials; for the group, vergence responses followed target presentation after a median interval of 183 msec. To determine whether anticipatory vergence movements depended on a memory of prior stimuli, trials were run in four subjects in which oddball stimuli required a different-sized vergence movement. Most responses to oddball stimuli were not significantly different from responses to the preceding stimuli.

CONCLUSIONS. Anticipatory vergence movements occur commonly in response to predictable stimulus movements in depth, but uncommonly when the timing of stimulus presentation is not predictable. The speed of anticipatory vergence movements is affected by stimulus amplitude. Properties of these movements are influenced by prior vergence responses, indicating that they depend on working memory. (*Invest Ophthalmol Vis Sci.* 2002;43:2626-2632)

Under natural conditions, most shifts of our point of visual fixation are between objects that lie in different directions and at different distances in the environment.¹ Changes in the direction of gaze are achieved by saccades, and shifts of the depth of fixation by vergence.² When subjects track a target that jumps at regular intervals between two target locations

that are in different directions but similar distances, anticipatory movements may precede each saccade.³ This phenomenon has been widely studied,³⁻⁷ and it has been proposed that these anticipatory movements are due to the smooth-pursuit system, because they are impaired in patients with cerebellar disease who show poor pursuit.⁷ The vergence system has also been shown to possess predictive properties,⁸⁻¹⁰ but these have not been characterized so systematically. The goals of the present study were to determine (1) how frequently anticipatory vergence occurs in normal subjects, (2) whether the magnitude of anticipatory vergence velocity is affected by the size of the required vergence change, and (3) whether anticipatory vergence responses are dependent on a memory of prior stimuli. Preliminary results have appeared in abstract form.¹¹

METHODS

Subjects and Recording Methods

We studied 10 healthy human subjects (age range, 24-54 years), 7 of whom were naive as to the purpose of the experiments. All subjects gave informed, written consent. The study was conducted in accordance with the tenets of the Declaration of Helsinki and was approved by the Institutional Review Board of Cleveland VA Medical Center.

We measured horizontal and vertical movements of each eye using the magnetic search-coil technique, with 6-foot field coils that used a rotating magnetic field in the horizontal plane and an alternating magnetic field in the vertical plane.¹² Search coils were calibrated before each experimental session. The SD of system noise was less than 0.02° and cross talk between horizontal and vertical channels was less than 2.5%. The curve relating coil rotation on a protractor to the signal measured from the system over a range of ±20° was within 98.5% of a straight line.

Visual Stimuli

Subjects alternately switched their point of fixation between near and far targets, both aligned as closely as possible to their midlines (Fig. 1). The far visual stimulus was a red laser spot at a distance of 1.2 m, and the near target was a green LED at either 20 or 36 cm, in a dimly lit room. Each target was alternately illuminated in a predictable sequence, every 1.25 seconds (0.4 Hz). For each near target position, we carried out three 40-second runs, so that there were 48 cycles for each target position. Subjects were instructed to "look at the target that lights up, and stay with it as it jumps." They were given encouragement throughout the sessions to "stay with the target," taking short rest periods between each experimental run.

We performed two control experiments in five subjects. First, we measured responses when the near and far stimuli were presented with unpredictable timing (multiples of 1.25 seconds, determined by random number generator) to determine whether this abolished anticipatory vergence responses. Second, we measured responses to ±30° horizontal target jumps at 0.4 Hz on the tangent screen, to determine whether these subjects also made conjugate anticipatory movements with saccades, as previously reported.^{3,7}

To investigate further whether anticipatory vergence movements depend on a "working memory" of prior stimuli, we ran trials in four of our subjects in which an oddball stimulus was presented. In these experiments, the target motion was basically periodic, but after a

From the Departments of ¹Biomedical Engineering and ⁴Neurology, Veterans Affairs Medical Center and University Hospitals, Case Western Reserve University, Cleveland, Ohio; the ²Department of Ophthalmology, Great Ormond Street Hospital for Children National Health Service Trust, and the ³Department of Visual Science, Institute of Child Health, London, United Kingdom.

Supported by the Office of Research and Development, Medical Research Service, Department of Veterans Affairs; National Eye Institute Grant EY06717; and the Evenor Armington Fund.

Submitted for publication December 21, 2001; revised April 15, 2002; accepted April 26, 2002.

Commercial relationships policy: N.

The publication costs of this article were defrayed in part by page charge payment. This article must therefore be marked "advertisement" in accordance with 18 U.S.C. §1734 solely to indicate this fact.

Corresponding author: R. John Leigh, Department of Neurology, University Hospitals, 11100 Euclid Avenue, Cleveland, OH 44106-5040; rjl4@po.cwru.edu.

EXPERIMENTAL SETUP

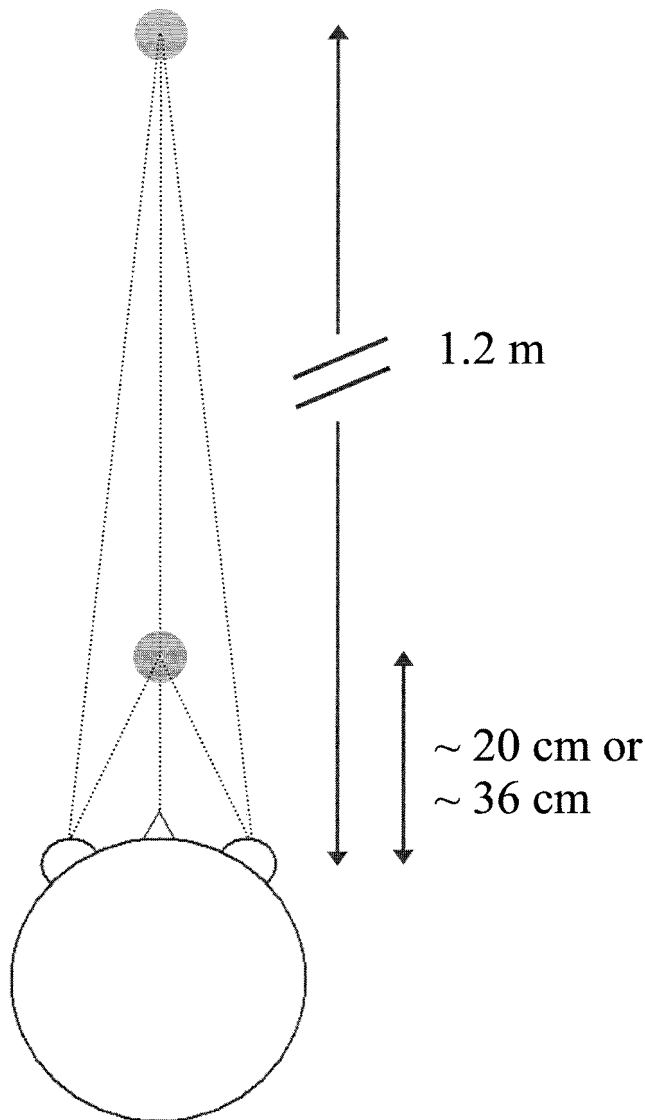

FIGURE 1. Geometric arrangement of experimental stimuli. Subjects shifted their point of fixation between a far target at 1.2 m and a near target lying at either 20 or 36 cm.

random number of cycles, an unexpected change was made in the amplitude of the target—the “oddball.” Subjects were informed that some stimuli might be different, but were encouraged to “stay with the target.” Subjects viewed a red laser spot that was projected from above onto a nearly horizontal plank of wood in front of them, just below eye level. The laser spot stepped between two standard distances (20 and 90 cm) except for the oddball stimuli that were 25% of all jumps. For the divergence oddballs, the spot jumped from the standard near target (20 cm) to 60 cm for decreased divergence and 120 cm for increased divergence. For the convergence oddballs, the spot jumped from the standard far target (90 cm) to 10 cm for increased convergence and 50 cm for decreased convergence. The timing between target jumps was 1.25 seconds, but the subject did not know when the oddball stimulus would occur. All target locations were aligned with the subject’s midline.

Data Analysis

To avoid aliasing, coil signals were passed through Krohn-Hite Butterworth filters (bandwidth, 0–150 Hz) before digitization at 500 Hz with 16-bit resolution. These digitized coil signals were filtered and differentiated, as previously described.¹² Version was calculated as (right horizontal gaze plus left horizontal gaze)/2. Vergence angle was obtained by subtracting right horizontal gaze from left horizontal gaze; this signal was filtered (bandwidth, 0–30 Hz) and then differentiated to yield a vergence velocity signal with noise typically less than 0.5 deg/sec.

Even with careful alignment, a small saccade with vertical and horizontal components accompanied almost every vergence response; this is consistent with prior reports.¹ A representative response is shown in Figure 2A. We separately analyzed the components of the vergence response that preceded and followed the saccade onset. The anticipation period (negative response latency) of the vergence movement was calculated as the time period by which the vergence movement preceded the target jump. We defined the start of the vergence movement when vergence velocity exceeded 1.5 deg/sec.⁷

We excluded the first response of each run, because this was evoked by a target jump that could not be predicted. For each response, we measured the time at which the vergence movement started, the time at which the small saccade began, and the time of occurrence of peak vergence speed. Thus, as shown in the example in Figure 2A, the pre-saccadic part of the response lies between points A_d (beginning of response) and B_d (onset of saccade) for divergence, and between A_c and B_c for convergence. We measured the persaccadic response between points B_d (onset of saccade) and C_d (peak vergence speed) for divergence, and between B_c and C_c for convergence. In this study, we used mean pre- and persaccadic vergence velocity values as measures of responses, because they were less influenced by any oscillations, postsaccadic drifts, or noise than a single measurement of peak velocity. We compared mean vergence velocities of responses to near targets at 36 cm versus 20 cm, as well as the timing of onset of saccades made during these responses. Statistical comparisons were made with either a *t*-test or Mann-Whitney rank-sum test, depending on whether data were normal in distribution.

RESULTS

Frequency of Occurrence of Anticipatory Vergence Movements

All subjects showed some anticipatory responses; the frequency of occurrence and the anticipation period are summarized in Table 1. Representative data are shown in Figure 2A. Overall, divergence responses were anticipatory in 83% of the trials, whereas anticipatory convergence responses occurred in 70%. For the group of subjects, median anticipation period for all vergence responses was 191 ms.

Comparison of the Speed of Components of Anticipatory Convergence and Divergence

The mean velocities of anticipatory vergence responses from the group of subjects are summarized in Figure 3A. For either convergence or divergence movements, persaccadic vergence velocities were significantly greater than corresponding presaccadic components ($P < 0.001$). We also compared the speed of convergence and divergence responses of the group of subjects, analyzing separately the presaccadic and persaccadic components. In all but one case, divergence was faster than convergence ($P < 0.001$), the exception being presaccadic convergence and divergence responses for the near target at 36 cm, which were not significantly different.

A. REPRESENTATIVE RESPONSE TO PREDICTABLE VERGENCE STIMULUS

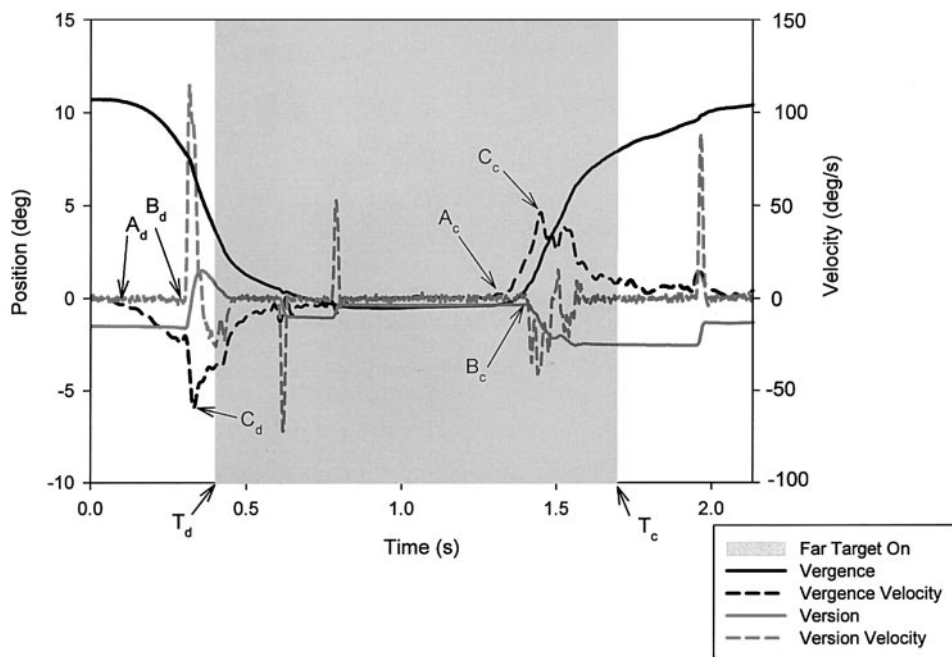
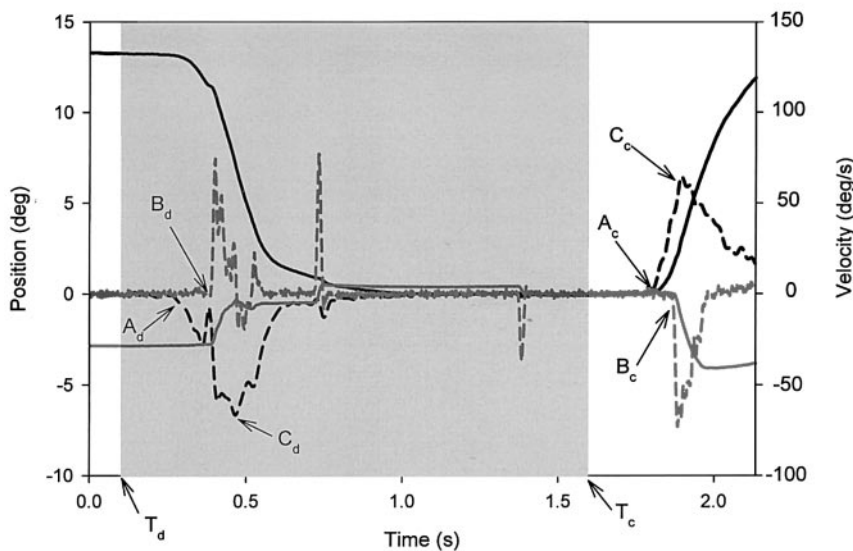

FIGURE 2. (A) Representative responses to predictable stimulus motion. At the onset of the record, the subject is converged approximately 12° , but commences a divergence movement (A_d) approximately 0.4 seconds before the near visual target goes off and the far target goes on. Gray area corresponds to when the far target is on. The velocity records show an initial presaccadic phase (A_d - B_d). After a small saccade, vergence speed increases for approximately 200 ms to a peak (C_d). The final part of the vergence movement is slower and finishes after the target jump (T_d). The second response in the record consists of an anticipatory convergence movement that shows similar phases preceding (A_c - B_c), during (B_c - C_c) and after a saccade. Positive deflections indicate convergence and rightward movements. Note different scales for position and velocity on left and right axes. (B) Representative responses to unpredictable target motion. Symbols and conventions are similar to (A). Note that the vergence-saccade response follows target motion. See text for details concerning measurement of responses.

B. REPRESENTATIVE RESPONSE TO UNPREDICTABLE VERGENCE STIMULUS



Comparison of Anticipatory Vergence Responses to Near Targets Located at 20 or 36 cm

For the group of subjects, we separately compared pre- and postsaccadic components of vergence responses when the near target was positioned at 20 cm versus at 36 cm; these data are also summarized in Figure 3A. Responses were significantly greater ($P < 0.001$) in all cases when the target was located at 20 cm. Individually, all subjects showed significantly greater velocities for the near target at 20 cm ($P < 0.05$), except in the case of presaccadic convergence, when only five subjects showed significant differences. We also compared the anticipation period of vergence responses for near stimuli at 20 versus 36 cm. For divergence,

the anticipation period was significantly greater ($P < 0.01$) for the 20-cm near stimulus (group median 231 ms, interquartile range 246 ms) than the 36-cm near stimulus (group median 200 ms, interquartile range 173 ms). For convergence, the anticipation period was not significantly different for the 20-cm near stimulus (group median 260 ms, interquartile range 190 ms) compared with the 36 cm near stimulus (group median 247 ms, interquartile range 202 ms). Table 1 contains median values based on combined data from both target positions. Individually, no subject showed differences in the anticipation period for convergence responses to the two near stimuli; for divergence responses, subjects 3 and 10 showed significantly greater anticipation

TABLE 1. Summary of Rate of Occurrence and Length of Anticipation Period

Subject	Anticipatory Convergence		Anticipatory Divergence	
	Occurrence (%)	Period (ms)*	Occurrence (%)	Period (ms)*
1	86.4	247 (3-642)	97.9	292 (19-702)
2	100.0	290 (31-789)	94.7	156 (3-397)
3	96.7	271 (98-485)	100.0	290 (82-498)
4	95.6	293 (52-673)	95.6	301 (19-660)
5	41.1	103 (9-337)	91.7	194 (2-517)
6	66.3	187 (2-549)	75	144 (1-554)
7	5.6	90 (26-186)	43.3	66 (8-206)
8	78.4	144 (4-424)	61.2	111 (4-354)
9	34.8	99 (4-244)	79.3	188 (10-648)
10	96.5	318 (22-608)	93.4	290 (14-654)

* Median (range) of pooled predictive responses with the near target at 36 and 20 cm.

periods to the 20-cm target, whereas subject 5 showed the converse ($P < 0.001$).

To determine whether the timing of the small saccades that occurred with each response could account for the difference in vergence responses to near targets at the two viewing distances, we compared the timing of these saccades for trials with targets at 20 cm versus 36 cm using the Mann-Whitney rank-sum test. The group of 10 subjects showed no significant difference of the time period from saccade onset to stimulus onset for the 20-cm stimulus (group median, 114 ms; interquartile range, 106 ms) versus the 36 cm stimulus (group median, 113 ms; interquartile range, 111 ms). Individually, six subjects showed no difference, whereas three showed a significantly longer period from saccade onset to stimulus onset for responses to the 20-cm stimulus ($P < 0.05$), and one subject showed a longer period from saccade onset to stimulus onset for the 36-cm stimulus ($P < 0.01$).

Results of Control Experiments

In response to unpredictable target presentation, the five subjects tested showed vergence movements that preceded stimulus onset in only 1.8% of trials (range 0%-3.9%). Representative responses are shown in Figure 2B and pooled data from the five subjects are summarized in Figure 3B. Thus, almost all vergence responses followed the target presentation. In this group of five subjects, vergence responses followed target presentation by a median interval of 183 ms. As a group, convergence speed was greater than divergence for corresponding near targets (located at 20 or 36 cm), the difference being significant for targets located at 20 cm ($P < 0.005$). When corresponding vergence responses to predictable and unpredictable targets were compared (corresponding boxes in Fig. 3A and 3B), velocities were significantly greater ($P < 0.05$) in every case for unpredictable targets, with the exception of presaccadic divergence responses with the 20 cm near target, for which the predictive responses were faster ($P < 0.05$). All the five subjects tested showed some anticipatory conjugate movements in response to horizontal target jumps $\pm 30^\circ$ at 0.4 Hz, similar to those previously reported.⁷

Responses to Oddball Stimuli

When we compared each response to an oddball stimulus with the response that preceded it (Fig. 4), there was no significant difference of the presaccadic component in three of the four subjects (paired *t*-test). Three subjects responded to the oddball stimulus with the same-sized presaccadic vergence movement as for the preceding stimulus, and then after the actual target jump, they made a corrective vergence movement. Only

subject 4 showed responses to convergent, but not divergent, oddball stimuli that were significantly different from the preceding stimulus (Fig. 4). To better understand this discrepancy, we compared the anticipation period of the four subjects for responses to the oddball stimulus and found that subject 4 often waited until after the target jumped before responding to convergent oddball stimuli. Thus, her anticipation period for convergent oddball stimuli (median, -97 ms) was significantly different ($P < 0.05$) from the anticipation period (median, 73 ms) of the other three subjects. None of the subjects showed a tendency to wait for divergent oddball stimuli. We also compared the period from stimulus presentation to onset of the small saccades occurring with responses to oddball versus non-oddball stimuli (Mann-Whitney rank-sum test) and found no significant difference.

DISCUSSION

Our main findings in these experiments were (1) vergence movements that occur in anticipation of predictable target jumps were common in normal subjects; (2) vergence movements seldom preceded stimulus onset when the timing of target motion was unpredictable; (3) the speed of anticipatory vergence movements was influenced by the magnitude of the vergence stimulus, being faster when the near stimulus was positioned at 20 cm versus 36 cm; and (4) the speed of each anticipatory vergence response was similar to the prior response. We discuss the significance of each of these findings, comparing the behavior with anticipatory conjugate movements, which have received more systematic study.

All our subjects developed anticipatory vergence movements in response to predictable target jumps between near and far locations. Most subjects showed anticipatory responses in over 70% of trials, making them as common a phenomenon as conjugate movements in anticipation of predictable changes in the direction of the target.³⁻⁷ For our group of subjects, the median anticipatory interval was 191 ms, which is similar to conjugate anticipatory movements.⁷ During control experiments, in which target jumps were made unpredictable, vergence movements only rarely preceded stimulus onset; this behavior is also similar to conjugate movements with unpredictable jumps.⁷ The median latency to onset of vergence responses after presentation of these unpredictable stimuli was 183 ms, which is similar to prior reports,⁹ but approximately 100 ms longer than the shortest vergence responses.¹³ These differences in vergence latency measurements may be attributed to different visual stimuli (small- versus large-field) and to the mental set of the subjects. Thus, in our experiments,

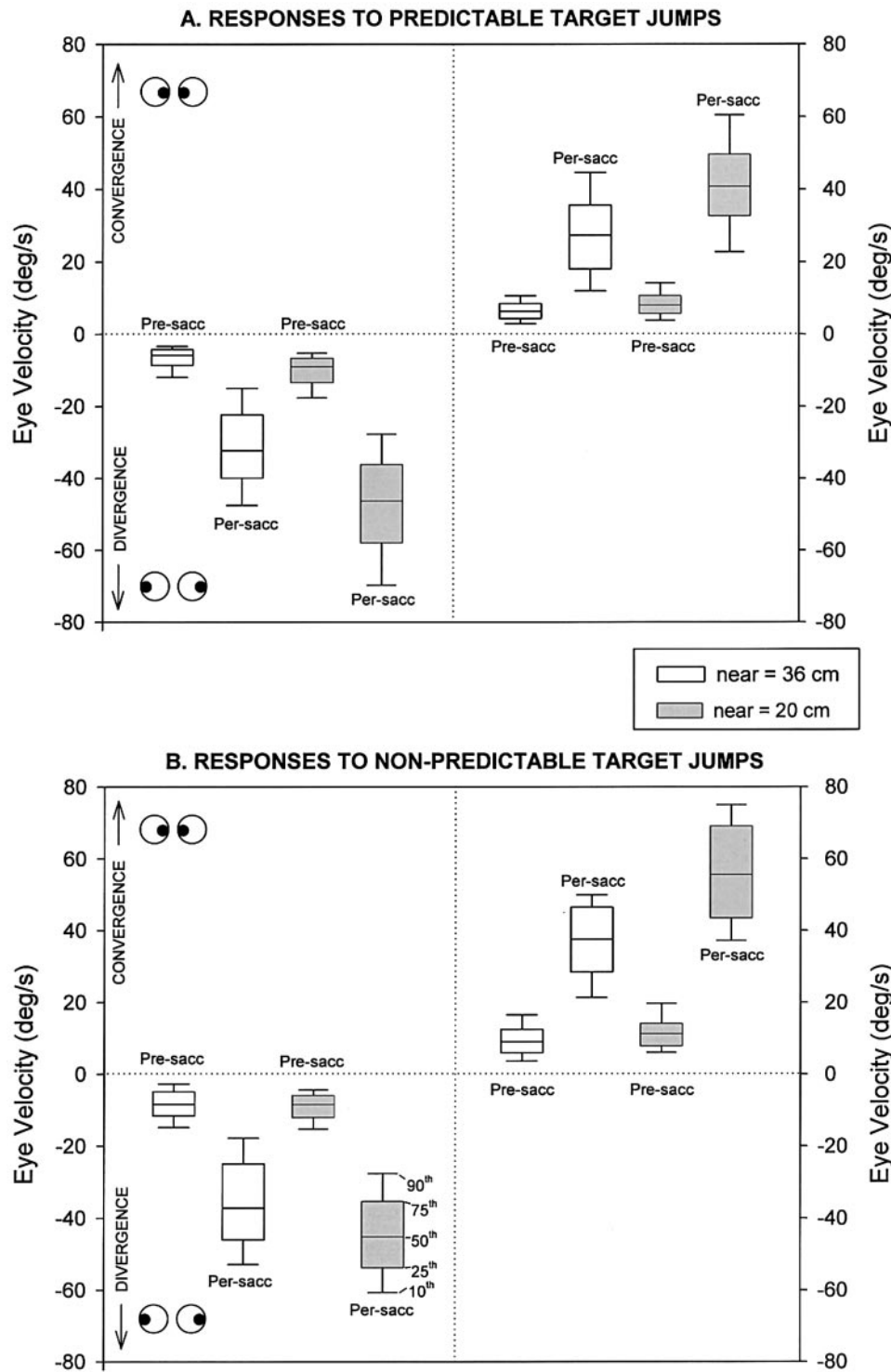

FIGURE 3. Tukey box plot summarizing pre- and persaccadic convergence and divergence mean velocity values. (A) Pooled data from the group of 10 subjects in response to predictable target jumps. (B) Pooled data from five subjects for the control experiment in which target jumps were unpredictable. The boxes display 10th, 25th, 50th (median), 75th, and 90th percentiles. In each panel, the four boxes at *left* summarize divergence responses; the four boxes at *right* summarize convergence responses. Responses to near targets located at 36 cm are displayed separately from response to near targets located at 20 cm. Statistical comparisons between different responses are described in the Results section.

vergence responses to predictable target jumps typically led responses to visual stimuli by approximately 370 ms.

Most anticipatory responses consisted of a vergence movement and a small saccade (Fig. 2A), which is the most common behavior even for targets aligned on the midline.¹ As previously noted, the persaccadic components of the anticipatory vergence responses had higher peak velocities than presaccadic components¹⁰; both were influenced by the amplitude of the

target jump (Fig. 3). A similar trend is reported with conjugate anticipatory movements, with larger (50° versus 1.5°) changes in target direction inducing faster (40 deg/sec versus 2 deg/sec) movements.^{3,7} Could the anticipatory vergence movements that we measured be influenced by changes in the timing of the saccadic component of the response? To examine this issue, we compared the timing of the saccadic component for responses to near targets at 20 cm versus 36 cm; overall,

COMPARISON OF RESPONSES TO ODDBALL STIMULI WITH RESPONSES TO PRIOR STIMULI

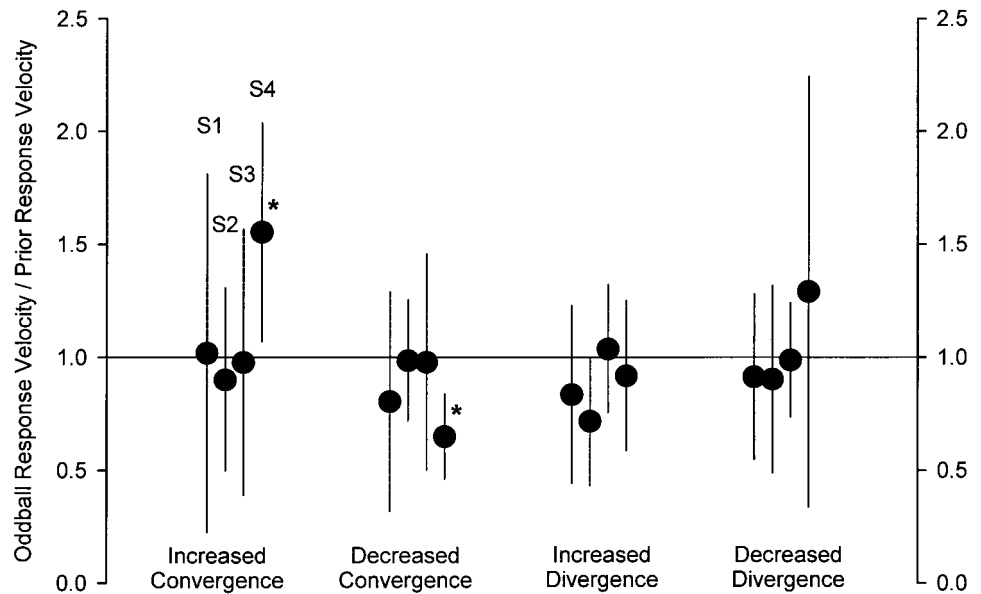

FIGURE 4. Comparison of presaccadic mean velocity vergence responses to oddball stimuli and the prior, predictable stimuli for 4 subjects (S1-S4); see text for explanations. Plots show mean (dot) \pm SD (lines) of the ratio: velocity of responses to oddball stimuli/velocity of response to the prior stimulus. If the vergence velocity of the response to the oddball stimulus was the same as that of the prior stimulus, the ratio should be 1.0. The four types of oddball stimulus (compared with the prior stimulus) are indicated at the bottom. Only subject 4 showed significant differences between the two responses for convergent stimuli (*indicates $P < 0.05$, paired t -test).

there was no difference. Furthermore, we noted that when subjects made small vertical saccades in response to small target jumps on the tangent screen, no vergence movements were evident, although they showed some conjugate anticipatory movements. Thus, we tentatively conclude that the anticipatory disjunctive movements that we report originate from the vergence, not the saccadic, system. However, our evidence is indirect, and it remains possible that the saccadic component influences the presaccadic part of the vergence response.

An unexpected finding was that anticipatory divergent movements were generally faster than anticipatory convergent movements (Fig. 3A). This is the opposite of the trend for most, but not all, prior studies of nonanticipatory vergence responses to target jumps,^{1,2,14} as well as our control experiments with unpredictable target jumps (Fig. 3B). Further studies are required to confirm this result.

Prior studies of conjugate movements have suggested that anticipatory responses depend on a history of prior target motions.^{15,16} We tested this hypothesis for anticipatory vergence movements by presenting oddball stimuli that varied in the magnitude of the target jump, even though the timing was unchanged. Most subjects showed responses to such oddball stimuli that were not different from responses to the prior stimulus, supporting the idea that anticipatory vergence responses are dependent on a working memory of prior stimuli. Only in the case of convergence did one subject show responses that were different from the prior stimulus, a result that can be explained by the subject's tendency to wait until after the target jumped before responding.

Caution should be applied in generalizing the results to the stimuli selected for these experiments to the behavior of vergence movement in general. However, it seems possible that anticipatory vergence movements might provide a useful method to test patients with neurologic disease affecting either the cerebellum,⁷ or the cerebral hemispheres.¹⁷⁻¹⁹ Thus, for example, adjacent frontal eye fields, which contain saccadic, pursuit, and vergence units,²⁰ might impair both anticipatory conjugate and vergence responses.

Acknowledgments

The authors thank Mark Morrow for making available equipment for stimulus presentation and to Radom Pongvuthithum for technical assistance.

References

1. Collewijn H, Erkelens CJ, Steinman RM. Voluntary binocular gaze shifts in the plane of regard: dynamics of version and vergence. *Vision Res.* 1995;35:3335-3358.
2. Zee DS, FitzGibbon EJ, Optican LM. Saccade-vergence interactions in humans. *J Neurophysiol.* 1992;68:1624-1641.
3. Kowler E, Steinman RM. The effect of expectations on slow oculomotor control. I: periodic target steps. *Vision Res.* 1979;19:619-632.
4. Boman DK, Hotson JR. Stimulus conditions that enhance anticipatory slow eye movements. *Vision Res.* 1988;28:1157-1165.
5. Kao GW, Morrow MJ. The relationship of anticipatory smooth eye movement to smooth pursuit initiation. *Vision Res.* 1994;34:3027-3036.
6. Barnes GR. Visual-vestibular interaction in the control of head and eye movement: the role of visual feedback and predictive mechanisms. *Prog Neurobiol.* 1993;41:435-472.
7. Moschner C, Zangemeister WH, Demer JL. Anticipatory smooth eye movements of high velocity triggered by large target steps: normal performance and effect of cerebellar degeneration. *Vision Res.* 1996;36:1341-1348.
8. Rashbass C, Westheimer G. Disjunctive eye movements. *J Physiol.* 1961;159:339-360.
9. Krishnan VV, Farazian F, Stark L. An analysis of latencies and prediction in the fusional vergence system. *Am J Optom Arch Am Acad Optom.* 1973;50:933-939.
10. Yuan W, Semmlow JL, Munoz P. Effects of prediction on timing and dynamics of vergence eye movements. *Ophthalmic Physiol Opt.* 2000;20:298-305.
11. Kumar AN, Han Y, Garbutt S, Dell'Osso LF, Leigh RJ. Anticipatory vergence drifts. *Soc Neurosci Abstr.* 2001;27:404.14.
12. Ramat S, Somers JT, Das VE, Leigh RJ. Conjugate ocular oscillations during shifts of the direction and depth of visual fixation. *Invest Ophthalmol Vis Sci.* 1999;40:1681-1686.

13. Busetini C, Fitzgibbon EJ, Miles FA. Short-latency disparity vergence in humans. *J Neurophysiol.* 2001;85:1129-1152.
14. Hung GK, Zhu H, Ciuffreda KJ. Convergence and divergence exhibit different response characteristics to symmetric stimuli. *Vision Res.* 1997;37:1197-1205.
15. Kowler E, Martins AJ, Pavel M. The effect of expectations on slow oculomotor control. IV: anticipatory smooth eye movements depend on prior target motions. *Vision Res.* 1984;24:197-210.
16. Wells SG, Barnes GR. Fast anticipatory smooth-pursuit eye movements appear to depend on a short-term store. *Exp Brain Res.* 1998;120:129-133.
17. Braun DI, Boman DK, Hotson JR. Anticipatory smooth eye movements and predictive pursuit after unilateral lesions in human brain. *Exp Brain Res.* 1996;110:111-116.
18. Lekwuwa GU, Barnes GR. Cerebral control of eye movements. II: timing of anticipatory eye movements, predictive pursuit and phase errors in focal cerebral lesions. *Brain.* 1996;119:491-505.
19. Sawaguchi T, Goldman-Rakic PS. The role of D1-dopamine receptor in working memory: local injections of dopamine antagonists into the prefrontal cortex of rhesus monkeys performing an oculomotor-delayed response task. *J Neurophysiol.* 1994;71:515-528.
20. Gamlin PD, Yoon K. An area for vergence eye movements in primate frontal cortex. *Nature.* 2000;407:1003-1007.